

110% MIXING SOLUTIONS



www.ystral.com

Ystral[®]
110% MIXING SOLUTIONS



110% MIXING SOLUTIONS

With our comprehensive knowledge and long-time experience as a manufacturer of machines and processing systems we develop solutions together with our customers for their specific application, that provide an immediate and quantifiable added value.

We accompany them with our passion and full engagement through all processing steps.

Whether for the Chemical Industry, Pharmaceutical Industry, Cosmetic Industry or for the Food Industry – at ystral you can find the solution for your specific application – from laboratory scale up to production equipment.

As a medium sized, owner-managed enterprise with subsidiaries in Singapore and India coupled with numerous representatives world-wide, we are well positioned for any future demands.

ystral – A Think Tank in Process Technology. Call for us!



Mixing
Powder wetting
Dispersing
Jetstream mixing
Wet grinding
Emulsifying
Homogenising
Stirring

110% MIXING SOLUTIONS



Some samples of applications



Adhesives
Agrochemicals
Anti-foams
Battery gels
Catalysts
Concrete additives
Enzyme solutions
Fiber, foil and films
Floor coatings
Foams
Home Care
Mineral oils
Paper coatings
PVA-solutions
Sealants
Seed coatings
Synthetics
etc.

Automotive OEM and
refinish paints
Coil and container coatings
Decorative paints
Floor Coatings
Industrial coatings
Marking paints
Printing inks
Wood protection lacquers
and glazes
etc.

Creams
Deodorants
Fragrances
Gels
Hair lacquers
Hand washing paste
Lip stick mass
Lotions
Nail varnish
Natural cosmetics
Perfume and flavouring
Pigment pastes
Soaps
Shampoo
Sun protection
Tooth paste and tooth gel
etc.

Aromas
Baby food
Chocolate masses
Dips
Drinks
Fats
Honey
Ice cream pre-mix
Margarine
Marmalades and jams
Milk products
Mustard
Parfait
Sauces and dressings
Soft drinks
Starch solutions
etc.

Active agent coatings
Cough syrup
Enterale food
Gels
Juices
Ointments
Vaccines
etc.

CONTENTS

| | Page |
|--|---|
| ystral – A Think Tank in Process Technology | 6 |
| YSTRAL Jetstream Mixer | Mixing without air induction 8 |
| YSTRAL Dispermix | Mixing and dispersing in one workstep 10 |
| YSTRAL X-Batch Disperser | Batch dispersing 12 |
| YSTRAL TDS-Induction Mixer | Powder induction and mixing 14 |
| YSTRAL Multipurpose | "All in One" – Jetstream Mixer, Dispermix, Batch Disperser etc. 16 |
| YSTRAL Z-Inline-Disperser | Inline dispersing 18 |
| YSTRAL Conti-TDS | No. 1 in powder wetting 20 |
| YSTRAL PiloTec and PiloTec-Plant | ystral Technology in laboratory and pilot plant scale 22 |
| ystral Engineering and Consulting | Customer tailored solutions 24 |
| ystral Plant Engineering | Modular components 26 |
| | Turn-key processing systems 28 |
| ystral Trial Centre | We share our know-how 30 |

ystral – A Think Tank in Process Technology

For more than 40 years

We owe our success to our knowledge, our experience – as well as our passion for our assignments and our customers.

ystral know-how constitutes the basis for our solutions. ystral encourages and supports that the knowledge is shared throughout the company. Our process- and application engineers for example continually participate in a long-term training and learning process, to successfully bring in their knowledge to the market. The result: they are part of the qualified specialists in their field and are known as experts world-wide.

The large portion of our employees in the field of engineering, process- and application engineering clearly shows the focal point of our enterprise and the core competence of ystral.

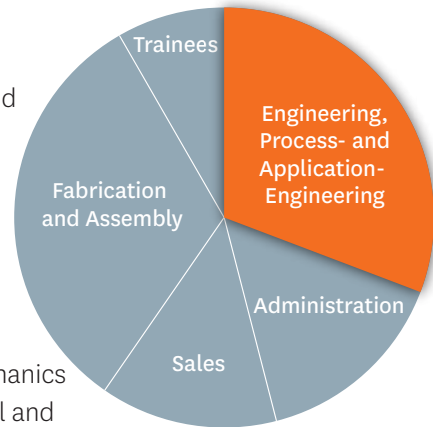

Our experts discuss the task at hand, in the mechanics of fluids at common level and share their knowledge while maintaining their attention to the details.

This generates solutions for your applications that fully deserve the affirmation "110% MIXING SOLUTIONS".



Our employees – the heads behind "110% MIXING SOLUTIONS"



Peter Manke and David Manke, Managing Directors



YSTRAL Jetstream Mixer

Constant product quality during mixing

The predominant mixing principle

An effective micro and macro mixing is mandatory to achieve a consistent quality of a product in a variety of applications. The YSTRAL Jetstream Mixer fulfils all the requirements that are necessary for a completely and homogeneous mixture in a vessel.

Therefore, economy, optimised mixing efficiency and simple handling are not compromised.

The essential advantages:

- Effective micro and macro mixing of the complete contents in the vessel without air induction
- Complete material exchange over all the levels due to a vertical mixing effect
- The applied energy is converted up to 90% in a vertical stream – no rotation of the contents in the vessel
- Even heavy sediments are suspended by the directed stream
- No free running shaft and mixing tools
- No Vortex is formed, no air is introduced
- Installation to the vessel from top, bottom, side or mounted on a moveable lift
- For open vessels, no special fixing devices are required



The function of the YSTRAL Jetstream Mixer:

- A fast rotating rotor produces a vertical flow of liquid inside the stator that is directed to the bottom of the tank/vessel.
- It is divided at the bottom and produces a flow upwards along the wall of the vessel.
- On the surface the liquid stream again is diverted towards the bottom of the vessel.



Technical Data

| | |
|------------------------|--|
| Power | 0,5 – 55 kW |
| Voltage | 230 / 400 V, 50 / 60 Hz, special voltages |
| Speed | 750 / 1.500 min ⁻¹ , 1.500 / 3.000 min ⁻¹ , infinitely variable speed up to 3.600 min ⁻¹ with a frequency converter |
| Bearing flange | coated aluminium, stainless steel 1.4404 (AISI 316 L) |
| Submersed parts | stainless steel 1.4404 (AISI 316 L), special materials |
| Seal | Lip seal, mechanical seal single or double action depending on operating conditions |
| Options | explosion proof execution, certifications, qualifications |



YSTRAL Dispermix

Mixing and dispersing in one workstep

Mixing and dispersing with only one machine

The YSTRAL Dispermix is used for applications where mixing only is not sufficient and additional dispersing is necessary. The Dispermix causes an intensive mixing of the contents of the vessel in the micro and macro range while simultaneously completely dispersing the product. Additional treatment with a shear ring disperser is in many cases unnecessary.

Due to an optimal mixing and dispersing efficiency, highest economy and ease of use of the installed mixing tools is given. The Dispermix fulfils the highest requirements to challenging production processes.

The essential advantages:

- Effective micro- and macro mixing of the complete contents in the vessel without air introduction
- Simultaneous disintegration of agglomerates and thus a better wetting
- Even heavy sediments are suspended and dispersed
- Different sizes of slots for easy adaption to the respective application
- No free running shaft and mixing/dispersing tools
- Installation to the vessel from top, bottom, side or mounted on a moveable lift



The function of the YSTRAL Dispermix:

- The Dispermix-head builds up two differently directed liquid streams.
- A vertical partial stream is directed towards the bottom of the tank, there it is separated and circulates the whole contents of the tank.
- A second partial stream in the mixing head is diverted horizontally and forced through the dispersing zone. Solid components and/or droplets are reliably reduced in size and homogeneously distributed in the liquid.

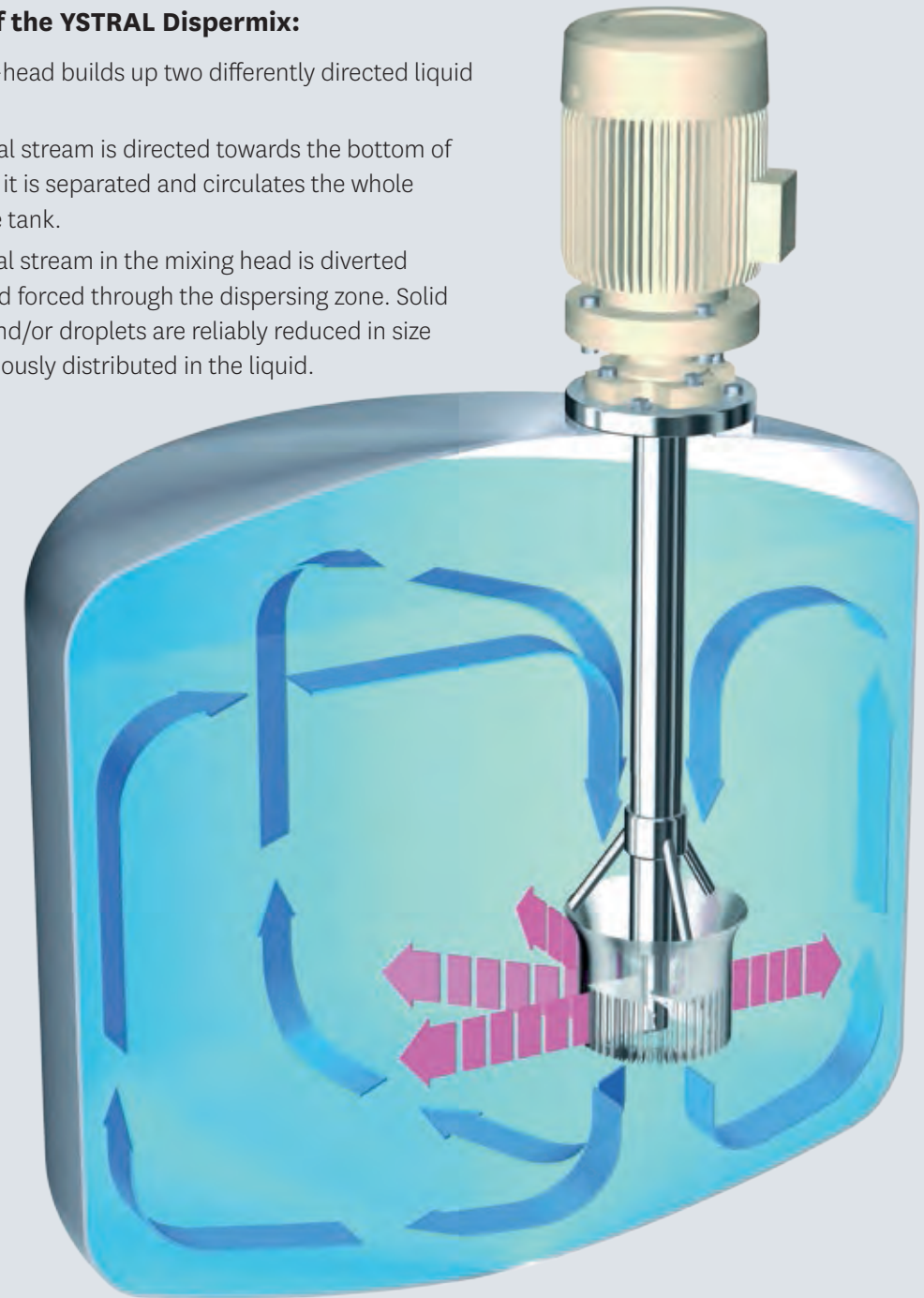

Technical Data

| | |
|------------------------|--|
| Power | 0,5 – 55 kW |
| Voltage | 230 / 400 V, 50 / 60 Hz, special voltages |
| Speed | 750 / 1.500 min ⁻¹ , 1.500 / 3.000 min ⁻¹ , infinitely variable speed up to 3.600 min ⁻¹ with a frequency converter |
| Bearing flange | coated aluminium, stainless steel 1.4404 (AISI 316 L) |
| Submersed parts | stainless steel 1.4404 (AISI 316 L), special materials |
| Seal | Lip seal, mechanical seal single or double action depending on operating conditions |
| Options | explosion proof execution, certifications, qualifications |



YSTRAL X-Batch Disperser

Dispersing according to the Rotor-Stator-Principle

Highest shear gradients

The very fine distribution of solids (suspensions) and liquids (emulsions) in a basic liquid is achieved by a perfectly balanced interaction of different forces to reduce particle sizes.

Highly precise dispersing tools are individually adapted to the respective processing task.

The essential advantages:

- Robust rotor-stator-tools with a narrow radial gap provides a high shear gradient
- Using impact combined with a high frequency of compression and decompression processes, a very strong dispersing effect is achieved
- Solid components and/or droplets are reliably reduced in size and homogeneously distributed
- Different rotor-stator pairings allow an adaptation to the respective application
- Batch dispersing directly inside the vessel
- No rotation of the contents in the vessel – no Vortex builds up and no air is incorporated
- No free running shaft and dispersing tools
- Installation into the vessel from top, bottom, side or mounted on a moveable lift



The function of the YSTRAL X-Batch Disperser:

- Robust rotor-stator-tools with a narrow radial gap provide a high shear gradient.
- Impact and highly frequent pressure and decompression occurrence results in a strong dispersing effect.
- Solid components and/or droplets are reliably reduced in size and homogeneously distributed in the liquid.



Technical Data

| | |
|-------------------------|--|
| Power | 1,5 – 55 kW |
| Voltage | 230 / 400 V, 50 Hz, special voltages possible |
| Speed | 1.500 / 3.000 min ⁻¹ , infinitely variable speed up to 3.600 min ⁻¹ with a frequency converter |
| Bearing flange | coated aluminium, stainless steel 1.4404 (AISI 316 L) |
| Submersed parts | stainless steel 1.4404 (AISI 316 L), special materials |
| Seal | Lip seal, mechanical seal single or double action depending on operating conditions |
| Peripheral speed | 10 – 54 m/s |
| Options | explosion proof execution, certifications, qualifications |



YSTRAL TDS-Induction Mixer

Here no dust can occur at all

Dust reduced induction, suspending and dissolving of powders in liquids

YSTRAL TDS-Induction Mixers induct powders, liquids or gases below the level of the liquid and simultaneously homogenise the whole contents of the vessel.

The vacuum required for the induction is built up in the mixing head. The machine can be installed onto the top of a vessel by means of a flange or a traverse. As an alternative, the TDS-Induction Mixer can be attached to a lifting frame.

The essential advantages:

- Induct powder dust-free into a liquid, mixing and suspending with one machine
- Dust pollution during powder induction directly out of a paper sack is avoided
- Effective micro and macro mixing of the whole contents in the vessel with simultaneous powder induction
- Complete exchange of all materials and homogeneity over all the levels in the vessel because of the Jet-stream mixing principle
- Even liquids and gases may be inducted
- Immediate wetting below the level of the liquid
- No sticking of product to the wall of the vessel or installed devices
- No free running shaft and mixing tools



The function of the TDS-Induction Mixer:

- The powder is inducted out of a bag and transported into the liquid below the surface of the liquid, it is immediately mixed and wetted.
- The mixing head builds up the required vacuum (induction vacuum).

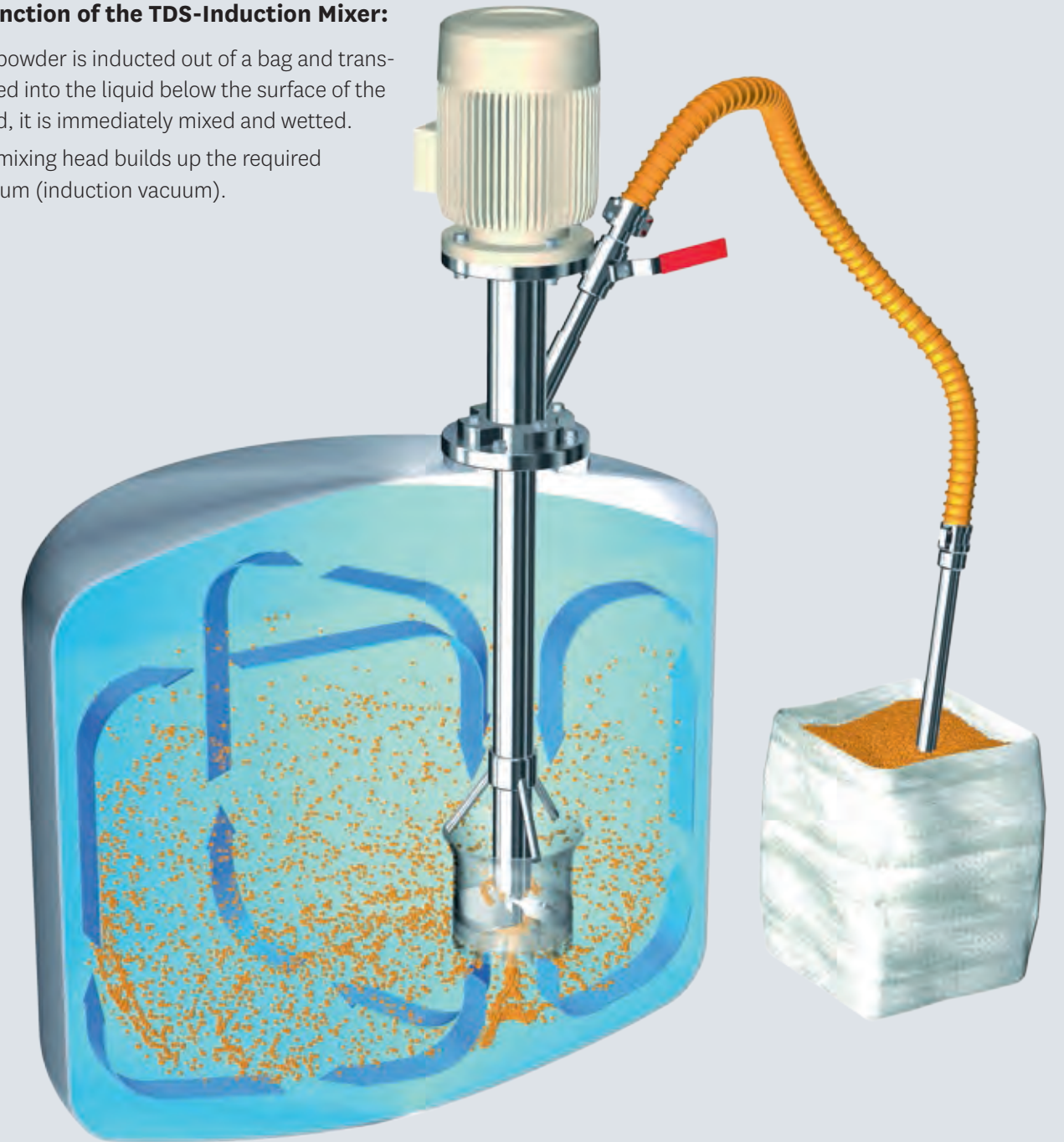

Technical Data

| | |
|------------------------|--|
| Power | 1,5 – 25 kW |
| Voltage | 230 / 400 V, 50 Hz, special voltages |
| Speed | 1.500 / 3.000 min ⁻¹ , infinitely variable speed up to 3.600 min ⁻¹ with a frequency converter |
| Bearing flange | coated aluminium, stainless steel 1.4404 (AISI 316 L) |
| Submersed parts | stainless steel 1.4404 (AISI 316 L), special materials |
| Seal | Lip seal, mechanical seal single or double action depending on operational conditions |
| Options | explosion proof execution, certifications, qualifications |



YSTRAL Multipurpose X50/X100/X200

Flexibility is trump

Multi-functional by exchangeable shafts and tools

The advantage of the YSTRAL Multipurpose-Elements is given by the modular set-up: exchangeable shafts and exchangeable mixing and dispersing tools. Up to now this was known primarily in the laboratory sector.

With the YSTRAL Multipurpose this advantage is also applied for the production equipment. With only one machine a variety of products and volumes may be treated with the most suitable tool. For the highest demands in hygienic fields of application, all connections are sealed according to the GMP guidelines.

Numerous variants for drives and lifting frames complete the Multipurpose systems.

The essential advantages:

- Highest flexibility provides certainty in the investment – short set-up times and simple handling
- Batch sizes from 5 up to 2.000 l are covered by the X50, X100 and X200 series
- Different variants for drives and lifting frames
- The adapter X100/X50 offers the possibility to produce batches with a volume of 5 up to 1.000 l with the X100 system
- By a simple exchange of the shafts you can use it as a Jetstream Mixer, a Dispermix, a Disperser or as a powder induction and wetting system

TOOLS



Jetstream Mixer:
Homogeneous mixing and suspending without incorporation of air



Dispermix:
Homogeneous mixing and dispersing in one step



HS-Dispermix:
Dispermix with increased shear effect



Batch Disperser:
Dispersing with highest shear gradient



TDS-Induction Mixer:
Dust-free induction and wetting of powders in liquids

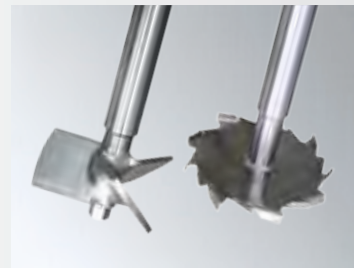

Other tools upon customer's request



Adapter for small batches:
The adapter allows the use of a X50 shaft in combination with a YSTRAL Multipurpose X100 (for a batch size starting with 100 l) to cover batch sizes in the range of 5 – 100 l.

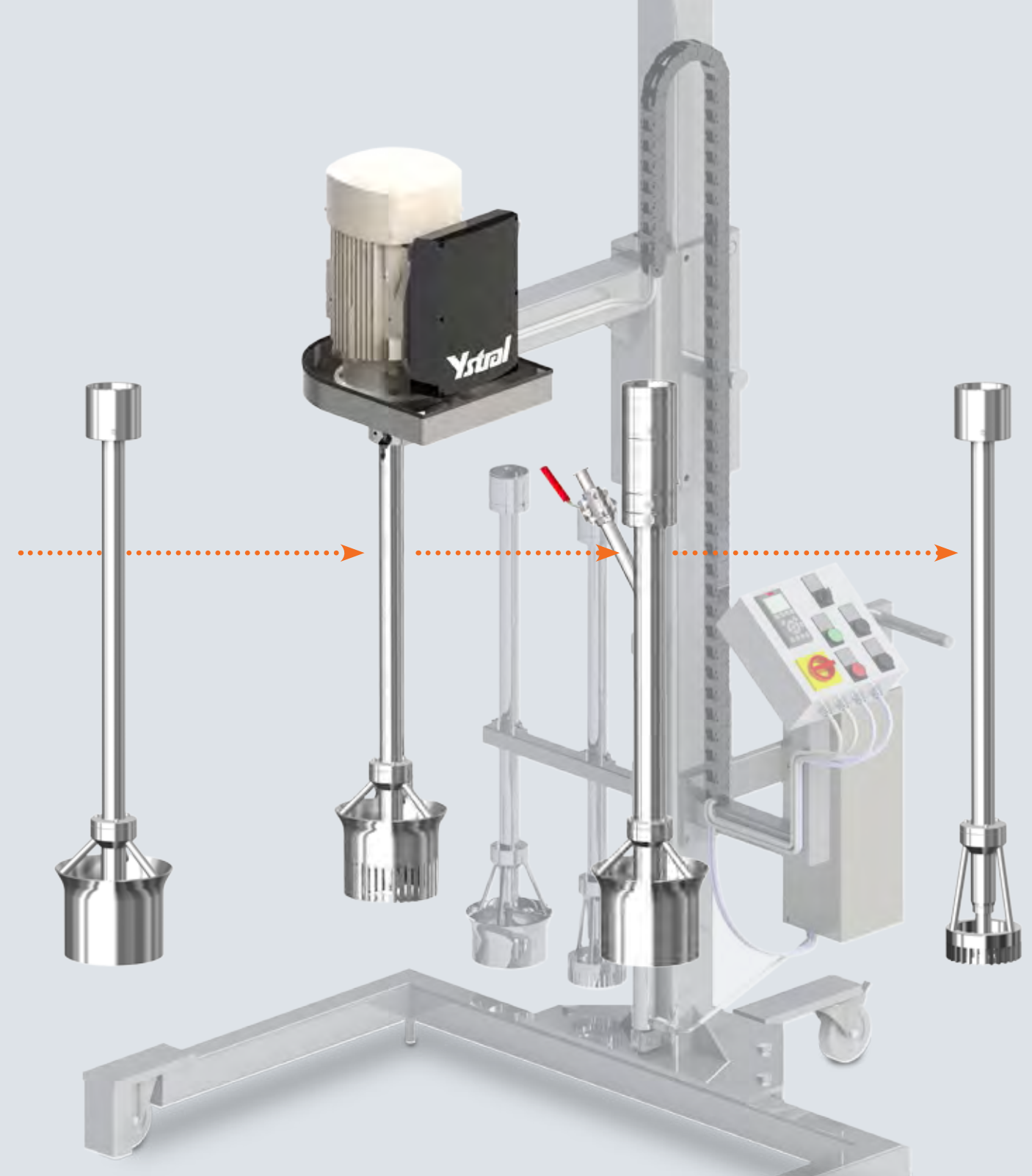

Technical Data

| | |
|------------------------|--|
| Power | 1,5 kW – 7,5 kW with exchangeable shafts and tools |
| Voltage | 230 / 400 V, 50 / 60 Hz, special voltages |
| Speed | 750 / 1.500 min ⁻¹ , 1.500 / 3.000 min ⁻¹ , infinitely variable speed up to 3.600 min ⁻¹ with a frequency converter |
| Shaft and tool | separated from the motor with bearing supported shaft, plug-in connection to the drive |
| Submersed parts | stainless steel 1.4404 (AISI 316 L), special materials |
| Seal | Lip seal, mechanical seal depending on operational conditions |
| Options | explosion proof execution, certifications, qualifications |



YSTRAL Z-Inline Disperser

Extreme fine distribution of suspensions and emulsions

High shear gradient with the Rotor-Stator-Principle

The YSTRAL-Inline Dispersing machines work according to the Rotor-Stator-Principle. Due to the narrow gap between rotor and stator and a very high peripheral speed of the rotating rotor a very strong shear gradient is created.

The product passes the slots in-between the teeth of the rotor and reaches the shear zone and leaves the same through the slots of the stator. Due to the multiple teeth geometries of both rotor and stator additional mechanical forces are applied to the product being dispersed.



The essential advantages:

- Batch dispersing in a loop or Inline dispersing in one passage
- Short and reproducible processes
- Precise and if required multi stage shear tools
- Narrow droplet spectrum for emulsions as well as a complete des-agglomeration for suspensions
- 3A Certificate – simple cleaning by CIP
- Self pumping for low to medium viscosity products
- Peripheral speed up to 54 m/s



The function of the YSTRAL Z-Inline Disperser:

- The product is guided through a rotor-stator-system.
- The inner rotor ring accelerates the product to maximum speed, the stator reduces the speed of the product to zero and then it is again accelerated by the next rotor ring.
- This results in a very efficient particle size and/or droplet size reduction and a homogeneous distribution of the particles.

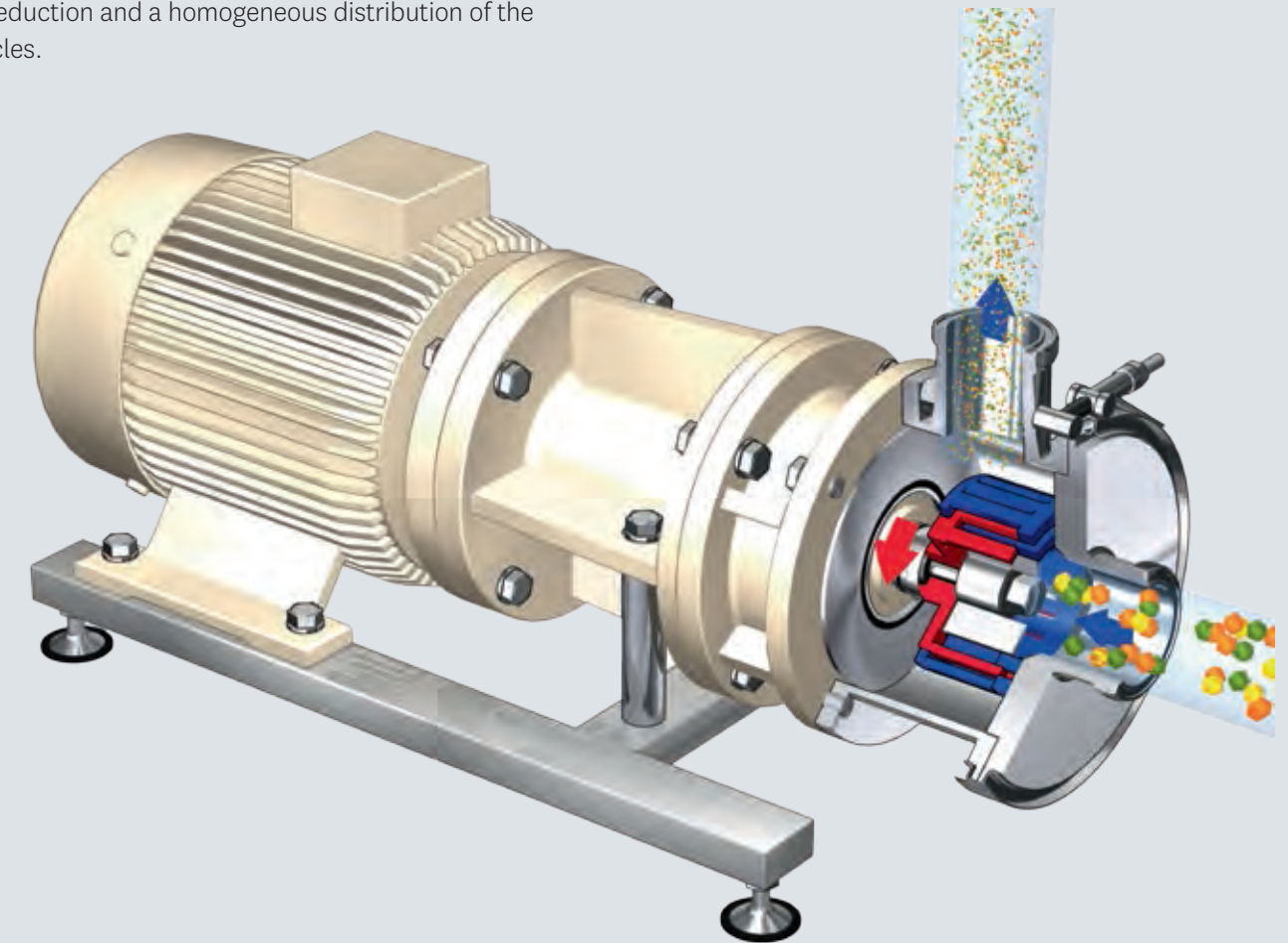

Technical Data

| | |
|------------------------------|--|
| Power | 1,5 – 55 kW |
| Voltage | 230 / 400 V, 50 / 60 Hz, special voltages |
| Speed | 750 / 1.500 min ⁻¹ , 1.500 / 3.000 min ⁻¹ , Infinitely variable speed up to 3.600 min ⁻¹ with a frequency converter |
| Dispersing chamber | stainless steel 1.4404 (AISI 316 L), special materials |
| Flow rate for liquids | 0,2 - 100 m ³ /h |
| Peripheral speed | 10 – 54 m/s |
| Seal | configuration depending on operational conditions |
| Options | explosion proof execution, certifications, qualifications |



YSTRAL Conti-TDS

No. 1 in powder wetting

Induction of powder, wetting and dispersing – with the YSTRAL Conti-TDS

Dust- and loss-free powder container emptying, powder transporting and then wetting and dispersing down to a complete des-agglomeration are realised within a single machine – the YSTRAL Conti-TDS.

Powders are not only wetted but dispersed into a liquid under vacuum. The formation of agglomerates is avoided. Higher efficiency incorporation of the raw materials and a better quality of the products are the natural result.

The combination of processing steps in one machine results in an enormous potential for process rationalising.

The essential advantages:

- Production times are minimised
- Partial processing steps are completely eliminated
- Cost of production is reduced
- Clean process due to dust- and loss-free powder induction, even for difficult to wet, sticky or dusty powders
- Induction and dispersing of powders directly from silo (with intermediate buffer), Big Bag, hopper, sack, barrel, etc.
- No adhesion to the vessel or installed components
- Fast and reproducible adjustment of the products due to an immediate and complete incorporation of the raw materials
- No induction of false air – powder transportation under vacuum in the dense phase



The function of the YSTRAL Conti-TDS:

- The YSTRAL Conti-TDS is based on the principle of an YSTRAL Inline dispersing machine.
- A special rotor-stator-system builds up a high vacuum and inducts powders dust- and loss-free directly into the liquid.
- The inducted powder immediately becomes dispersed under high shear.

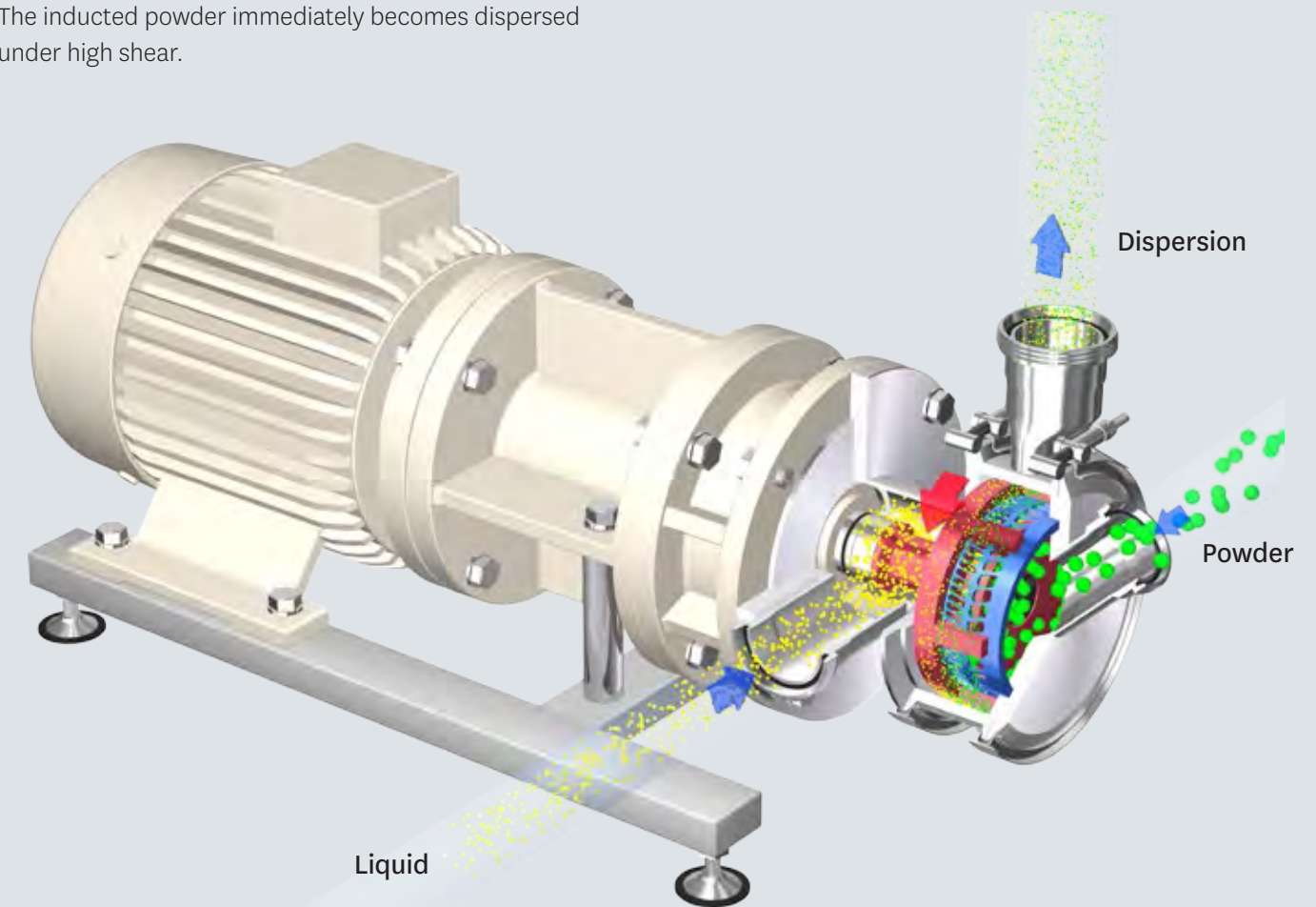

Technical Data

| | |
|------------------------------|--|
| Power | 5,5 – 250 kW |
| Voltage | 230 / 400 / 500 V, 50 Hz, special voltages possible |
| Speed | 1.500 / 3.000 min ⁻¹ , Infinitely variable speed up to 3.600 min ⁻¹ with a frequency converter |
| Dispersing chamber | stainless steel 1.4404 (AISI 316 L), special materials, tools exchangeable, fast clamping system |
| Flow rate for liquids | 10 - 200 m ³ /h |
| Induction speed | for powders up to 24 t/h |
| Maximal viscosity | 200.000 mPas (depending on size and use of the machine) |
| Seal | configuration depending on operational conditions |
| Options | explosion proof execution, certifications, qualifications |



YSTRAL PiloTec

ystral Technology in the laboratory and pilot plant scale

Our machines for your research and development

The newest generation of the multi functional YSTRAL PiloTec offers the possibility to use established production procedures at the laboratory scale. Based on Conti-TDS-technology powders may be inducted dust-free, wetted and dispersed under vacuum in a single process step.

A simple exchange of the tools allows the operation as an innovative Multi-Z- or Z-Inline-method with multi stage shear ring systems.

An established procedure with an energy input, independent of the batch size guarantee excellent and consistent results. These very easily may be transferred to the production scale – a safe scale-up to the ystral plant engineering.

The performance of the YSTRAL PiloTec:

- Induct, wet and disperse powders dust- and loss-free
- Emulsifying, homogenising, wet grinding and mixing
- Highest flexibility due to simple handling of the exchangeable tools
- CIP-capable
- Hygienic Design

Extension to the YSTRAL PiloTec-Plant

The modular design permits the extension to PiloTec processing systems with ystral mixing technology, systems for handling powders and liquids, monitoring and measuring and sensors, lifts and other modular components.



High flexibility

With the YSTRAL PiloTec we offer our numerous years of experience in industrial processes and flexibility with variable requirements. At any time you can switch from the YSTRAL Conti-TDS operation to the Multi-Z or Z-Inline operation.

The Conti-TDS operation provides dust and loss-free powder induction by a vacuum created in the mixing chamber.

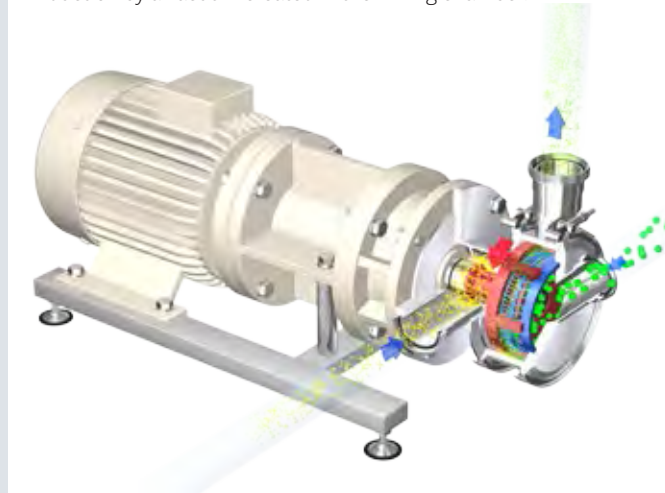

Multi-Z- or Z-Inline operation: In no time at all you can switch from the Conti-TDS operation to the Multi-Z or Z-Inline operation.

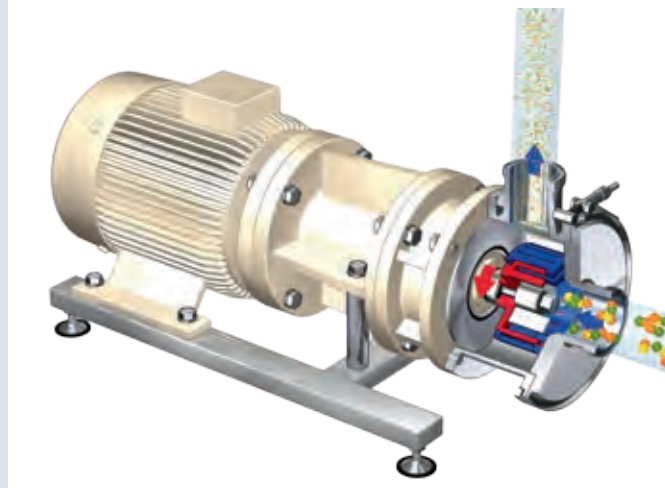

- Dust- and loss-free powder induction using the vacuum created inside the mixing chamber
- Powder induction via an induction tube directly from any container
- Induction of liquids for the production of emulsions
- Easy treatment of sticky, spontaneously swelling, strong foaming powders and powders which are difficult to wet
- Colloidal wetting and dispersing under vacuum
- Complete desagglomeration of the raw materials – higher quality products

- Inline dispersing inside the Conti-TDS-Chamber (Multi-Z)
- Multi stage shear rings with different shear gradients
- Perfect and reproducible dispersing results independent from viscosity in batch or Inline processes
- Shear speed up to max. 60 m/s
- Ideally suited for wet grinding

Technical Data

| | |
|------------------------------|---|
| Power | 4 kW |
| Voltage | 400 V, 50 Hz, special voltages |
| Speed | infinitely variable up to 12.000 min ⁻¹ with a frequency converter |
| Shear speed | up to 60 m/s |
| Dispersing chamber | 1.4404 (AISI 316 L) |
| Flexible batch sizes | from 5 l up to 200 l |
| Flow rate for liquids | 2-14 m ³ /h |
| Induction speed | for powders up to 15 kg/min |
| Seal | configuration depending on operational conditions |
| Options | explosion proof execution, certifications, qualifications |



ystral Engineering and Consulting

Customer tailored solutions for your specific applications

With our cross-industry expertise and passion we develop tailor-made solutions for your production. Your individual solution is our focus.

Whether for the Chemical, Pharmaceutical and Cosmetics Industries or for the Production of Food, besides individual machines ystral offers two primary solutions:

- 1. Modular components**
- 2. Processing systems**

Developed in co-operation

From laboratory to production scale: ystral processing systems are developed individually and in cooperation with you and are used as a standard world-wide.

A performance warranty offers the required assurance. The core of these all are our mixing, dispersing and powder wetting machines.

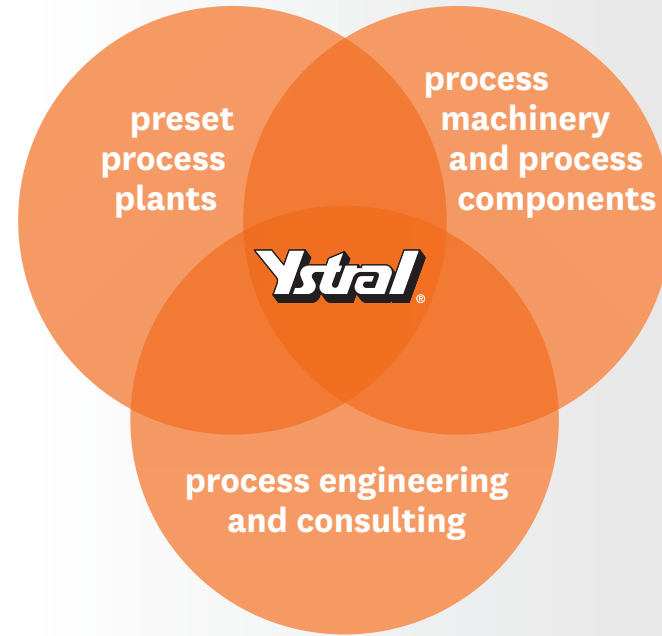

The developing process up to the readymade system is in one hand:



ystral Plant Engineering

Modular components around your system

Besides mixing, dispersing and powder wetting machines, ystral also offers a variety of modular components to cover upstream and downstream processes.

Powder and liquid handling, measuring and controlling techniques, automation, cleaning techniques, vessels and piping systems upon request complete the processing techniques.

Integrated components that are tuned to the specific application guarantee the highest efficiency.

Powder handling

With the YSTRAL Conti-TDS, you can induct powders and other solids directly into a liquid and disperse the same. To achieve a uniform and stable flow of the powder, we developed different components that may be individually adapted to your application.

Liquid handling

Our processing systems are linked with the treatment of liquids. For this reason, we have accumulated respective know-how that is part of our process engineering: Vessels, piping systems, pumps, valves, heat exchangers are integrated as well as filter systems and cleaning and monitoring systems. In addition, liquid components may be inducted and emulsified in a similar way as powders.

Control techniques

Recipe controlled and fully automatic processing systems or individually monitored control units. Weighing systems, controls for temperature and filling level sensors, CIP/SIP as well as visualization and documentation – you decide about the scope of supply.

We adapt our program to the existing system and we take care for a trouble-free integration.



Powder handling: Our daily challenge – Induct and disperse powders into liquids



Liquid handling: Inducting, emulsifying, storing, transporting, dosing, heating or cooling



Control techniques: It is your decision whether manual, semi or fully automatic operation

Processing systems manufactured by ystral may be combined as modules. This saves your time and cost.

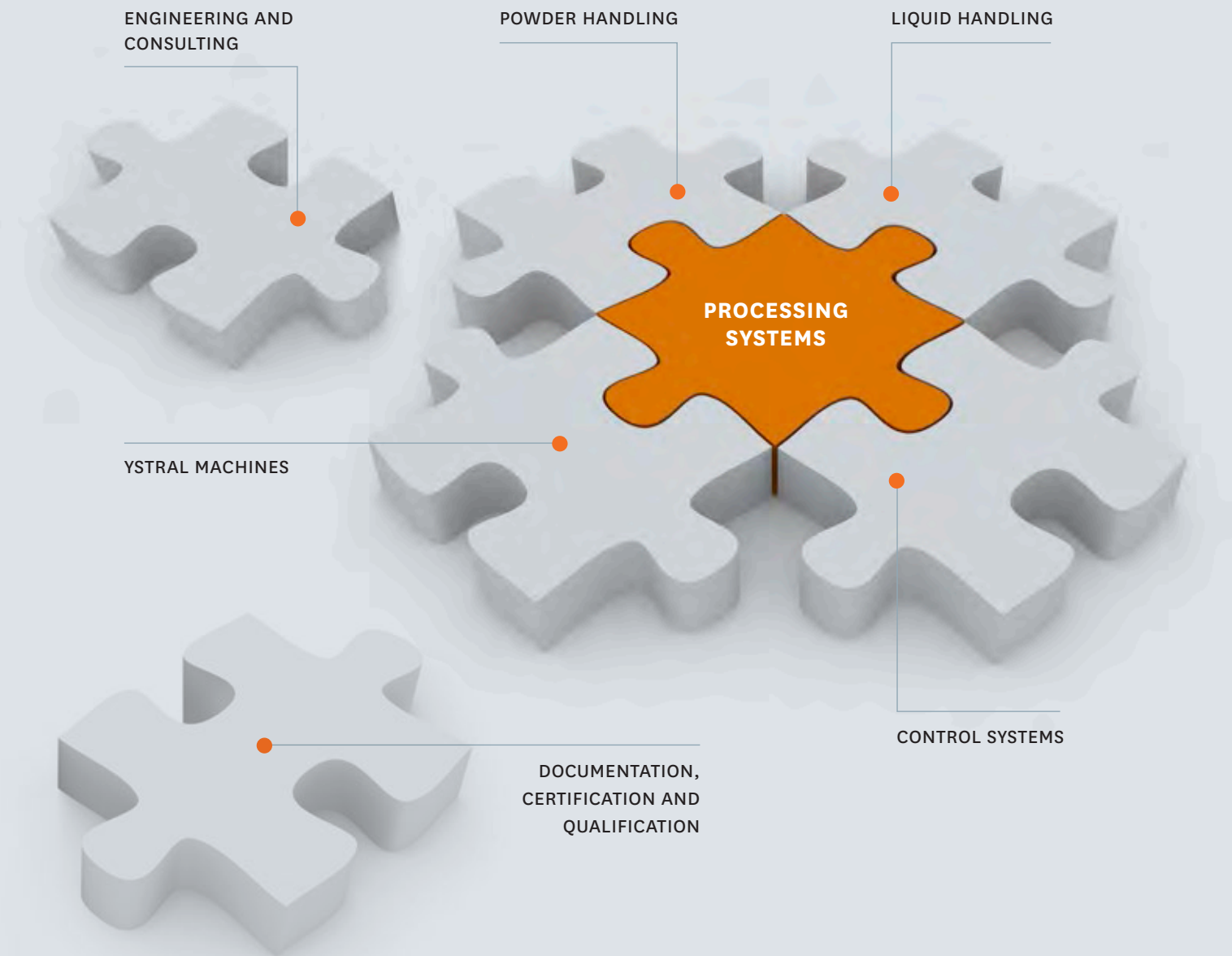

ystral Plant Engineering

Application specific processing systems – established in all branches

Paint and lacquers, adhesives, sealing and insulation compounds, coatings, spray emulsions, chocolate mass, milk products, active agent coatings, home care, personal care and many other products are already manufactured with ystral processing systems.

The economics and effectiveness of the production processes may be considerably improved with the help of our individual and space saving processing systems.

Our customers use processing systems developed by ystral as a standard worldwide.

The essential advantages:

- Economy and efficiency on the smallest footprint
- Significant savings by an optimal integration of different processing steps
- Our own process development and our own plant engineering
- Safe investment because of flexible, long lasting and reliable systems
- Cross-industry competence and more than 40 years of experience

Container systems that may be operated in different locations are available, just like our Skidded Units which are completely assembled on a base frame and can be considered as automatic production units.

Recipe control, visualisation, weighing, measuring and controlling techniques, vessels and piping systems, CIP systems – the units are assembled in our premises, tested by you under simulated production conditions and finally accepted. Once on your site our technicians will be ready to set-up and start-up the system and later on the respective service is provided.

This is the basis for the ystral processing guarantee.

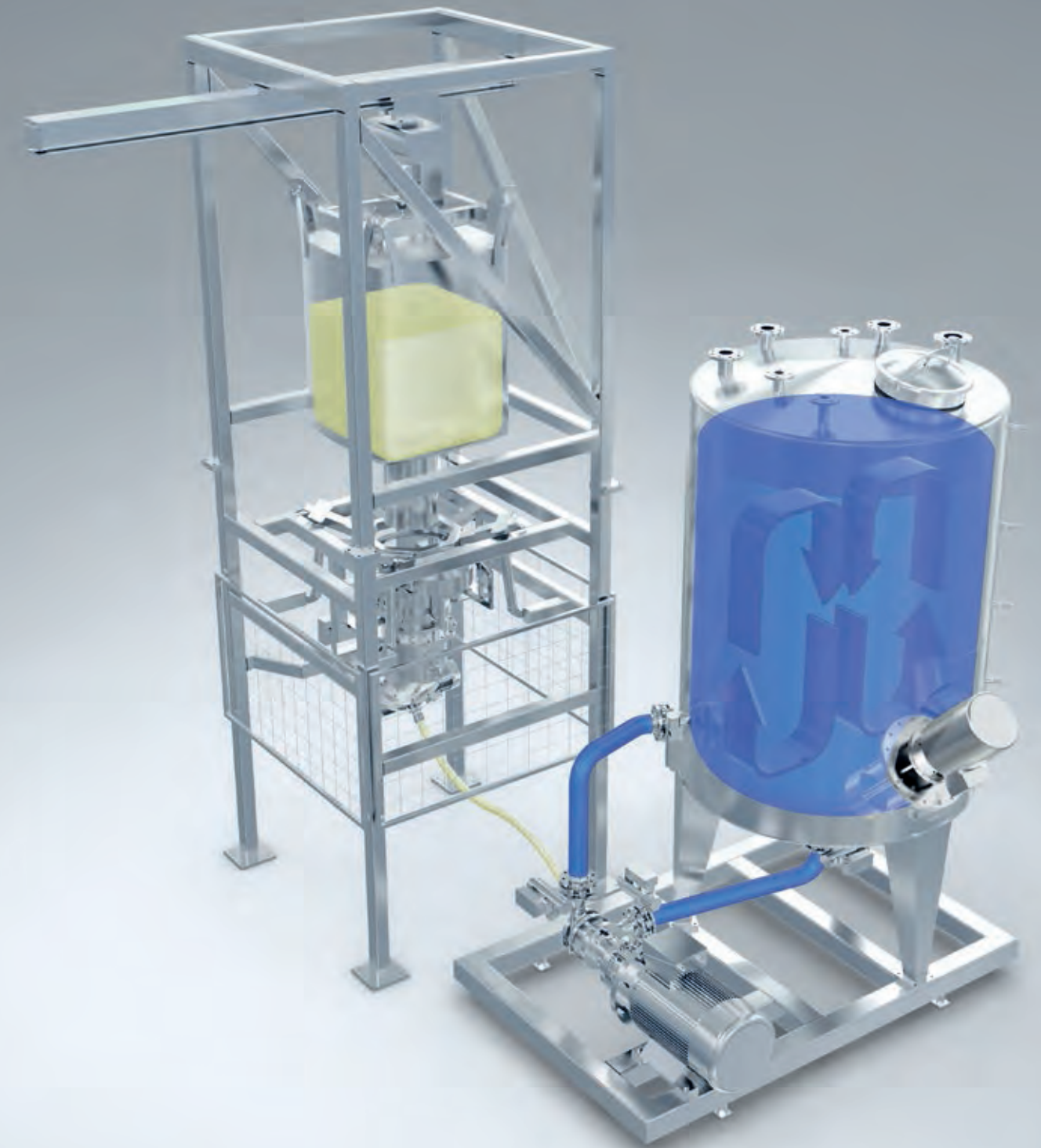

Ystral Trial Centre

We share our know-how

Together with our application engineers you can develop new processing technologies or improve existing processes.

In our premises we can provide almost the complete range of Ystral machines from laboratory scale to production size.

Learn more about your products and raw materials and carry out trials with the respective production machine or use the laboratory or pilot plant systems for future scale-up.

The essential advantages:

- Already more than 5.000 treated raw materials/solids
- Supervision by our process- and application engineers
- Documentation and analysis of the process parameters

Different measuring and analyzing devices with respective recording are the basis for an extensive documentation of the series of trials. To provide the necessary process safety we use this data as basis for our processing guarantee.

In addition, we offer the possibility to hire machines from our extensive pool of trial equipment. Upon request, we will accompany you with the trial during start-up on site.



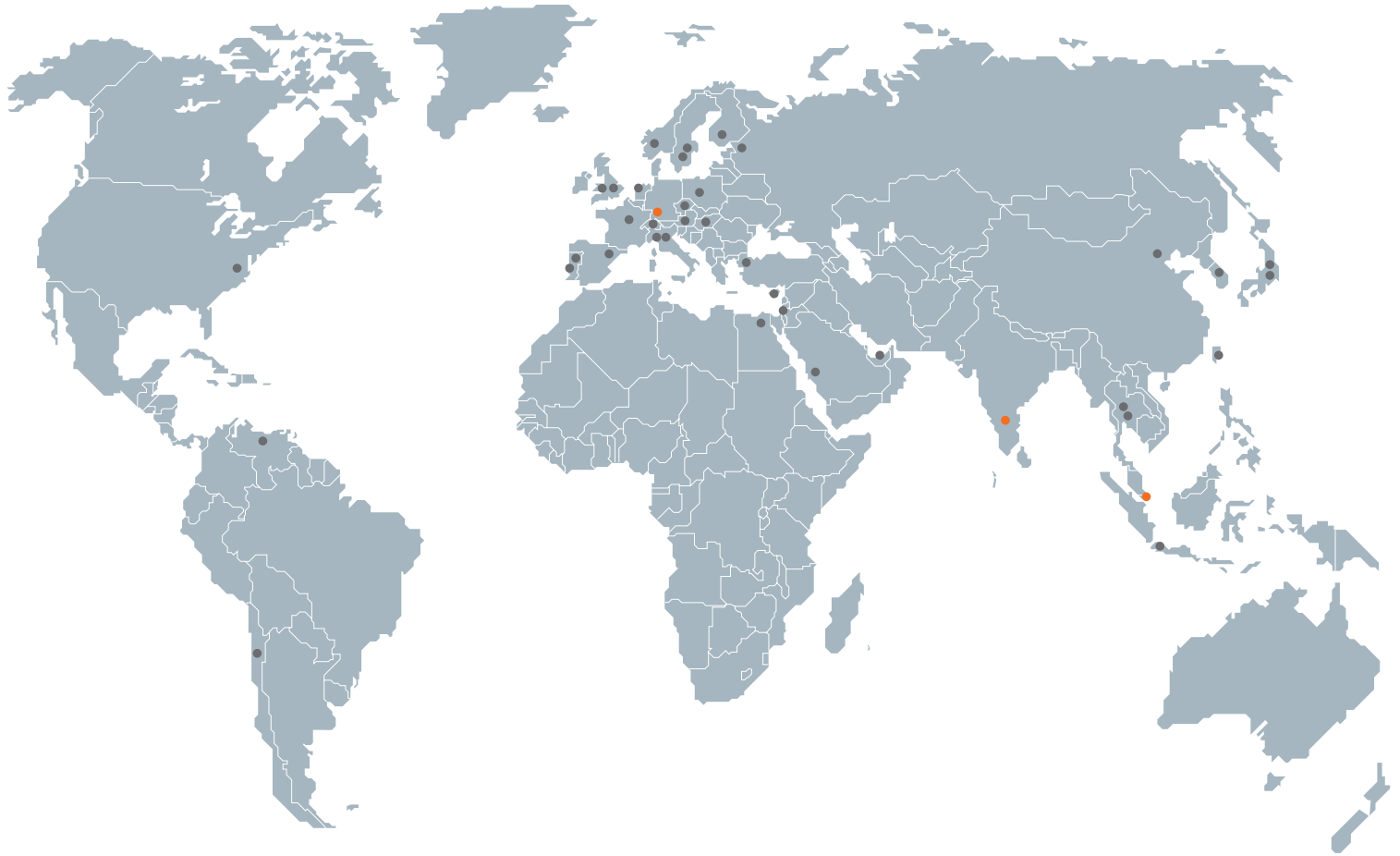

● Subsidiaries ● Representatives



110% MIXING SOLUTIONS

With our comprehensive knowledge and long-time experience as a manufacturer of machines and processing systems we develop solutions together with our customers for their specific application, that provide an immediate and quantifiable added value.

We accompany them with our passion and full engagement through all processing steps.

Whether for the Chemical Industry, Pharmaceutical Industry, Cosmetic Industry or for the Food Industry – at ystral you can find the solution for your specific application – from laboratory scale up to production equipment.

As a medium sized, owner-managed enterprise with subsidiaries in Singapore and India coupled with numerous representatives world-wide, we are well positioned for any future demands.

ystral – A Think Tank in Process Technology. Call for us!

Ystral[®]
110% MIXING SOLUTIONS

ystral gmbh
maschinenbau + processtechnik
Wettelbrunner Strasse 7
79282 Ballrechten-Dottingen
Germany

Tel. +49 7634 5603 - 0
Fax +49 7634 5603 - 99
ystral@ystral.de

www.ystral.com